

# Nano-Line

GB

Instruction Manual

nBoxX 1.7  
nBoxX 3.5  
nBoxX 5.0  
nBoxX 6.5



**KKT chillers contact:**

ait-deutschland GmbH  
Industriestrasse 3  
95359 Kasendorf  
Germany  
T +49 9228 9977 0  
F +49 9228 9977 149  
E [info@kkt-chillers.com](mailto:info@kkt-chillers.com)  
W [www.kkt-chillers.com](http://www.kkt-chillers.com)

**Service**

T +49 9228 9977 7190  
F +49 9228 9977 149  
E [service@kkt-chillers.com](mailto:service@kkt-chillers.com)

**Service Office USA**

KKT chillers, Inc.  
765 Dillon Drive  
Wood Dale, IL 60191  
T +01 833 558 4357  
F +01 847 734 1601  
TF +01 866 517 6867  
E [support@kkt-chillersusa.com](mailto:support@kkt-chillersusa.com)

**Service Office China**

KKT chillers East Asia  
Sales and Service Office  
5-1-D No. 333 Xingpu Road  
Modern Industrial Park, Suzhou 215021  
T: +86 512 6790 3091  
F: +86 512 6287 1077  
E: [service@kkt-chillerscn.com](mailto:service@kkt-chillerscn.com)

## Index

1.	Technical data.....	4
2.	Warranty.....	5
3.	Safety.....	5
3.1	Personal protection equipment:.....	7
4.	Residual risks.....	8
5.	Receiving and Unpacking.....	8
6.	Positioning the Chiller.....	9
6.1	Connections.....	10
7.	Process Water / Fluids.....	13
7.1	Waterquality.....	14
8.	Ambient temperature.....	15
9.	Start up of the chiller.....	15
9.1	Debug Table.....	19
10.	Main view.....	21
11.	Keys.....	22
12.	Parameters.....	22
13.	Thermostat Menus.....	24
14.	Errors table.....	28
	APPENDIX A.....	31
	APPENDIX B.....	32
	APPENDIX C.....	35
	APPENDIX D.....	36
	EC declaration of conformity.....	36

## 1. Technical data

nBoxX				
	nBoxX 1.7	nBoxX 3.5	nBoxX 5.0	nBoxX 6.5
Net Cooling capacity <sup>1)</sup>	1,7 kW	3,5 kW	5,0 kW	6,5 kW
Refrigerant	R134a			
GWP	1430			
Refrigerant filling	0,8 kg	1,5 kg		
CO <sub>2</sub> equivalent	1,14 t CO <sub>2</sub>	2,15 t CO <sub>2</sub>		
Ambient temperature range	15°C - 45°C			
Max air flow rate	1.300 m <sup>3</sup> /h	2.300 m <sup>3</sup> /h		
Coolant	Water and Glycol 80/20			
Tank volume	10 l	26 l		
Coolant outlet temperature	13°C - 35°C			
Temperature constancy	+ / - 2K			
Coolant flow	0,3 m <sup>3</sup> /h	0,8 m <sup>3</sup> /h	1,0 m <sup>3</sup> /h	1,1 m <sup>3</sup> /h
Pumping pressure	3 bar			
Sound pressure level <sup>2)</sup>	<62 dB(A)			
Operating voltage (+/-10%)	230 V / 1Ph / 50/60 Hz	400 V/3 Ph/50 Hz + 460 V / 3 Ph / 60 Hz		
Operating current	6,5 A / 7,5 A	6,5 A / 7,0 A	8,0 A / 8,5 A	9,5 A / 10,0 A
Power consumption	1,3 kW / 1,5 kW	2,5 kW / 3,1 kW	3,4 kW / 4,2 kW	4,1 kW / 5,0 kW
Protection class	IP 54			
Water connections	1/2 " IG	3/4 " IG		
Weight <sup>3)</sup>	67 kg	109 kg	111 kg	114 kg
Length	546 mm	727 mm		
Width	600 mm			
Height	634 mm	983 mm		
Color	RAL 7035			

1) at tw<sub>2</sub>=18°C, t<sub>amb</sub>=32°C, 50Hz, with pump 2) at 50 Hz, according to EN ISO 3741 3) without packaging and charge of coolant

## 2. Warranty

For informations about warranty please kontakt KKT Service

## 3. Safety

The Chiller instructions must be read by the installer and personnel in charge for operation, before starting the chiller.

All safety and security instructions given in this manual have to be observed!

Only qualified personnel are allowed to install, operate and do the maintenance work.

Non observance of the instructions may cause injuries and will cancel the manufacturers' liability for subsequent damage.



National regulations on accident prevention, regulations of the local power supply authorities as well as any specific safety instructions for chiller must be observed.

The safety of the unit is only guaranteed, if it is used as intended.

The following points must be observed before commissioning and while operating the Chiller:

- Familiarize yourself with all operating controls.
- Make sure that all working limits indicated within unit label are observed.
- Use protective devices to check electrical insulation. Do not carry out any work on any part of the equipment that are live with wet clothing, hands and feet.
- Never spill or pour any cooling medium into the environment as this may cause health hazard.
- The components of the Chiller must not be modified in any way.
- Disconnect the power supply and release pressure from any pressurized component before carrying out any service work on the Chiller.
- A qualified commissioning engineer must ensure that the Chiller has been connected to the electrical mains in accordance with the standard EN 60204 and all other applicable national regulations.

For Health and Safety reasons, please find below a list of potential risks that the operator is exposed to while commissioning and/or operating and/or dismantling the unit:

Risk	Recommended Safety Measure	Residual Risk to be aware of	Label
<i>sharp edges</i> (such as heat exchanger fins and internal metal plates live edges)	It is recommended to use safety equipment (such as gloves and protective cloths)	-	
<i>hot surfaces</i> (such as electric motor body of pump or compressor and refrigeration copper pipes)	It is recommended to use safety equipment (such as gloves and protective cloths)	-	
<i>refrigerant under pressures</i> within refrigeration circuit (PS indicated on chiller data label)	Always verify functionality of High Pressure Switch. Never open refrigeration circuit for maintenance before releasing pressure*	Due to Toxicity of refrigerant and oil still inside circuit, it is recommended to use suitable gloves and mask while servicing refrigerant equipment.	
<i>cooling water/glycol mixture under pressure</i> within hydraulic circuits (max pressure indicated on chiller data label)	Always check that all cooling water/glycol pressure is released before sectioning and servicing hydraulic equipment using purging system and refill ball valve	Due to Toxicity of glycol and oil still inside circuit, it is recommended to use suitable gloves and mask while servicing hydraulic equipment	

# English

<i>electrical shock</i>	Always disconnect power supply and post a 'MAINTENANCE WORK IN PROGRESS' sign on a visible position next to the main switch during service	-	
<i>rotating fans</i>	Always disconnect power supply and make sure all mechanical equipment is stopped before service.	-	
<i>Toxicity of refrigerant and cooling liquid</i>	It is recommended to use suitable protection equipment (such as gloves, glasses, safety shoes)	-	

**\*NOTE:** for environmental reasons never discharge refrigerant into atmosphere (follow local regulations to properly dispose of refrigerant).

It is recommended to familiarize with all technical documentation provided with the unit (such as controller manual, Mechanical & Electrical Diagrams) in order to avoid improper operation of this unit.

It is also mandatory to comply with Regulation (EU) No 517/2014 of the European Parliament and of the Council of 16 April 2014 on certain fluorinated greenhouse gases.

The above mentioned Regulation lays down specific measures and restrictions to be considered while commissioning, operating, maintaining and disposing any equipment containing greenhouse gases, such as HFCs, as specified in Annex I.

The Regulation (EU) No 517/2014 also (but not only) specifies mandatory leakage-check frequency to be performed by certified personnel and mandatory records providing the evidence of exact fluorinated gas charge and subsequent added and/or recovered quantities as described in Article 3 (reported below):

## Article 3 → Containment

Operators of the following stationary applications: refrigeration, air conditioning and heat pump equipment, including their circuits, as well as fire protection systems, which contain fluorinated greenhouse gases listed in Annex I, shall, using all measures which are technically feasible and do not entail disproportionate cost:

- (a) prevent leakage of these gases; and
- (b) as soon as possible repair any detected leakage.

Operators of the applications referred to in paragraph 1 shall ensure that they are checked for leakage by certified personnel who comply with the requirements of Article 5, according to the following schedule:

- (a) applications containing 5 tonnes of CO<sub>2</sub> equivalent or more of fluorinated greenhouse gases shall be checked for leakage at least once every 12 months; this shall not apply to equipment with hermetically sealed systems, which are labeled as such and contain less than 6 kg of fluorinated greenhouse gases;
- (b) applications containing 50 tonnes of CO<sub>2</sub> equivalent or more of fluorinated greenhouse gases shall be checked for leakage at least once every six months;
- (c) applications containing 500 tonnes of CO<sub>2</sub> equivalent or more of fluorinated greenhouse gases shall be checked for leakage at least once every three months.

The applications shall be checked for leakage within one month after a leak has been repaired to ensure that the repair has been effective.

For the purposes of this paragraph, 'checked for leakage' means that the equipment or system is examined for leakage using direct or indirect measuring methods, focusing on those parts of the equipment or system most likely to leak. The direct and indirect measuring methods of checking for leakage shall be specified in the standard checking requirements referred to in paragraph 7.

Where a properly functioning appropriate leakage detection system is in place, the frequency of the checks required under paragraph 2(b) and (c) shall be halved.

# English

In the case of fire protection systems where there is an existing inspection regime in place to meet ISO 14520 standard, these inspections may also fulfill the obligations of this Regulation as long as those inspections are at least as frequent.

Operators of the applications referred to in paragraph 1, containing 5 tonnes of CO<sub>2</sub> equivalent or more of fluorinated greenhouse gases, shall maintain records on the quantity and type of fluorinated greenhouse gases installed, any quantities added and the quantity recovered during servicing, maintenance and final disposal. They shall also maintain records of other relevant information including the identification of the company or technician who performed the servicing or maintenance, as well as the dates and results of the checks carried out under paragraphs 2, 3 and 4 and relevant information specifically identifying the separate stationary equipment of applications referred to in paragraph 2(b) and (c). These records shall be made available on request to the competent authority and to the Commission.







Regulation (EU) No 517/2014 also includes: 'Scope' – Article 1; 'Definitions' – Article 2; 'Recovery' – Article 4; 'Training and Certification' – Article 5; 'Reporting' – Article 6; 'Labelling' – Article 7; 'Control of Use' – Article 8; 'Placing on the Market' – Article 9; 'Review' – Article 10; Article 11; 'Committee' – Article 12; 'Penalties' – Article 13; Article 14; 'Entry into force'.



**CAUTION:** in accordance to the F-GAS regulation (EU) No 517/2014, every year the operator (the owner of the equipment) is responsible to ensure a Gas leakage test, the recording of the gas quantity change inside the unit and the communication to the responsible agency of the state in the European community where the unit is in operation.

To ensure that the performance of your chiller is not impaired, we recommend that you only use original spare parts purchased from KKT Chillers, in this way you ensure the reliability and quality of the machine. If you have any questions about spare parts, please contact our Service Team (Contact details, p.2). If you need any consultancy in terms of a maintenance and leakage check according (EU) No. 517/2014 please contact our Service Team. To ensure the proper and reliable functionality of the chiller, we recommend to perform the commissioning by our Service Team.

### 3.1 Personal protection equipment:

	<b>Wear foot protection!</b>
	<b>Wear hand protection!</b>
	<b>Wear eye protection!</b>
	<b>Wear protective clothing!</b>
	<b>Note and follow the instructions for use!</b>
	<b>Before opening the machine it must be disconnected from the power supply! After disconnecting the machine from the power supply, always wait for at least 5 minutes before opening it.</b>



**Danger! High voltage! If the machine is only switched off at its main switch, dangerous electrical voltage is still present at several terminals in the control cabinet.**

## 4. Residual risks

There are some residual risks after the installation of the unit that have to be considered:

### Residual risks according to 2006/42/EG Directive:

- The condenser has fins on his external surface, so there is the possibility for the operator to touch sharp edges during service of the unit.
- Although the unit is designed with all the possible safety requirements, in case of external fire there is the possibility that the internal pressure and temperature of the unit will increase in a dangerous and uncontrollable way; in that case use the extinguishing tools suitable for that conditions.
- For units without emergency switch-disconnector: chiller user must install the emergency switch-disconnector installation close to the chiller, in an accessible and clearly visible place, to allow emergency stop of the unit and safety for the operator.
- Even if the instructions contained in this manual are enough explanatory for safety, high pressure switches are mounted, to guarantee intervention in case of wrong filing, or in case of malfunction due to not controlled increase of pressure and temperature.

### Residual risks according to 2014/68/EU Directive:

- Although the unit is designed with all the possible safety requirements, in case of external fire there is the possibility that the internal pressure and temperature of the unit will increase in a dangerous and uncontrollable way; in that case use the extinguishing tools suitable for that conditions.
- For the series production of the standard units of category I, the pressure resistance test (typically the hydrostatic pressure test) is made on a statistic base, not on all units. This can be accepted, also considering all the safety devices mounted on the units.
- For units without emergency switch-disconnector: chiller user must install the emergency switch-disconnector installation close to the chiller, in an accessible and clearly visible place, to allow emergency stop of the unit and safety for the operator.
- Even if the instructions contained in this manual are enough explanatory for safety, high pressure switches/safety valves are mounted, to guarantee intervention in case of wrong filing, or in case of malfunction due to not controlled increase of pressure and temperature.

## 5. Receiving and Unpacking

Each chiller is supplied on a wooden pallet, wrapped with protective film, strapped, and protected on lateral sides.

Some units are also contained in a carton box.

It is recommended to pay particular attention during handling and transportation of the unit and to maintain the packaged units in the vertical position, in order to avoid any kind of dents to the external frame and any damage to the internal components.

Secure units to the transport vehicle with suitable strapping.

**Note!** The above mentioned packages are not suitable for piling up units on top of each other

Store the Chiller in a dry place, away from heat sources. All waste materials should be recycled in the appropriate manner.

For the operations of lifting and movement it is necessary to use a fork lift truck with proper load capacity and with forks longer than the base of the Chiller. Avoid sudden movements which can damage the framework and the internal components. Chiller is provided with 4 eyebolts for lifting and transportation, to



# English

be used for vertical loading/unloading only (to see the right point for lifting please refer to the stickers on the unit).



**Caution:** the chiller must be transported and moved without liquid/s in the tank/s

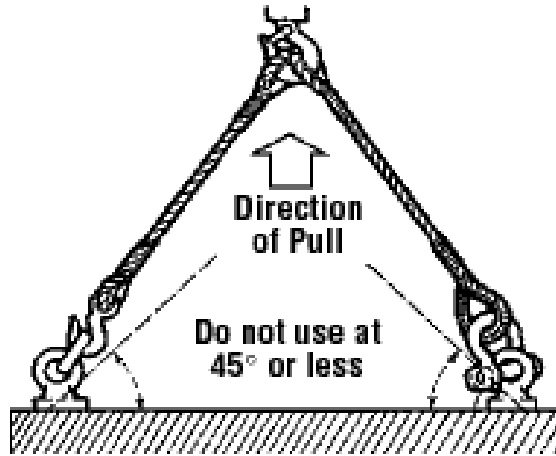

Picture 1 – Chiller lifting

Check after the final positioning of the Chiller the internal connections to avoid damage during operation.

## 6. Positioning the Chiller

Place the Chiller in an area shielded from any possible manufacturing residuals (shavings, dust, etc.) and well-ventilated, away from heat sources and direct influence of sun light; if possible, near the user system, in order to avoid load losses along the hydraulic connection pipes. Use the adjustable feet (where installed) to level off the cooling unit.

**Not intended use:** chiller can't be installed on mobile floor, or conveying vibrations, oscillating or inclined one.

The customer has to place a suitable room at disposal, as shown in the figure:

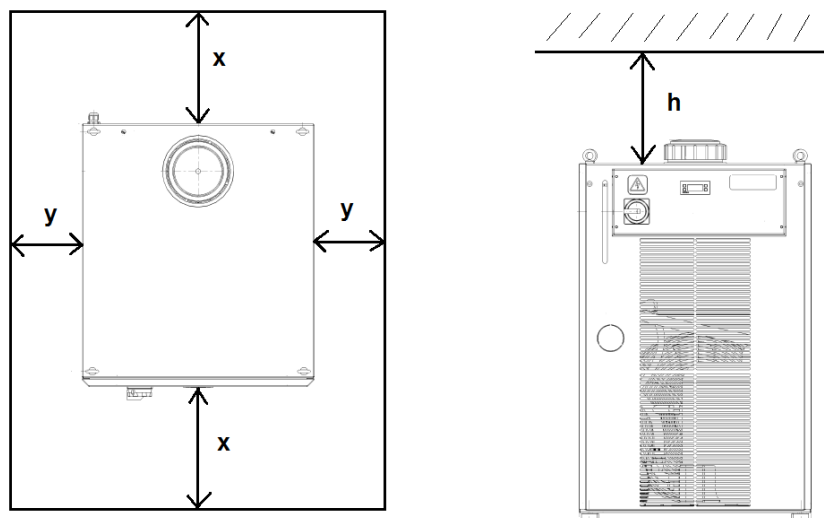

Picture 2 – Room minimum dimensions,  $x=1.5$  m (60 inches);  $y=0,5$ m (20 inches);  $h=0,5$ m (20 inches) for service and air suction

# English

---

According to CEI EN 60204-1, for units which don't have the lockable main switch at a minimum distance of 0,6 m (24 inches) from the basement of the unit, it's necessary to install that units in a position that allows to maintain that minimum distance.



**CAUTION:** For standard unit the outdoor installation is absolutely forbidden, even if under a roof. Only special designed outdoor units can be used in outdoor installation. For regular maintenance or adjustment, the chiller shall be located between 0,3 m (12 inches) and 1,0 m (40 inches) above the servicing level.

The chillers should be set on a concrete slab. The slab should extend a minimum of 30cm (12 inches) beyond the perimeter of the Chiller to prevent damage from lawn maintenance equipment, etc. The Chiller, which should be level and properly anchored, is provided with 4 antivibration dampers on the bottom of the unit, which allow the support and the fixing of the Chiller and to dampen the vibrations and decrease the noise during the operation.

## 6.1 Connections



**WARNING:** Hydraulic connections are the first ones to be assembled during installing operation, to be followed by electric connections. Remove the caps inside the hydraulic fittings connection before to connect the chiller to your device.



**WARNING:** The chillers has been cleaned by means of specific cleaning products. The eventual findings of solid particles in the hydraulic system might cause the loss of warranty.

**Hydraulic connections.** For the hydraulic connection please refer to the enclosed hydraulic plan. The flow rate and the fluid circulation direction must be respected during connection in accordance with INLET-OUTLET identification plates.



**CAUTION:** Connect hydraulic pipes before filling the tank (as described in the start-up procedure). Remove the caps inside the hydraulic fittings connection before to connect the chiller to your device.

## Example of Hydraulic connection plate



Picture 3 –Hydraulic connection plate  
nBoxX 1.7



Picture 4 –Hydraulic connection plate  
nBoxX 3.5  
nBoxX 5.0  
nBoxX 6.5

## Example of Electric connections

The unit must be electrically connected by the customer



Picture 5 – Electric connection

### Please Note:

- When units are provided without power and alarm cables (or industrial connectors), cable on terminal blocks into the electrical box, according to the e-plan enclosed with the unit
- Electrical installation must respect all valid safety standards.
- It's necessary to install protective fuses (indicated on the electrical plan) or a circuit breaker upstream of the power cable.
- Make sure the system is adequately earthed.
- Check that the voltage and frequency of the power supply correspond to the specifications on the unit's data plate and/or enclosed electrical plan.
- The Chiller units are designed for TN Earthing Systems. Use the Maximum fault loop Chiller Impedance value for sizing purposes on site (refer to  $Z_{pe}$  value specified within Electrical Diagram attached)

# English

- For units with (black) control main switch, emergency switch-disconnector (in accordance with IEC 60947-1, IEC 60947-2, IEC 60947-3) will be provided by customer in proximity of the unit



**CAUTION:** In case units that can work with different voltages (400V or 460V), connect the transformer of the auxiliary circuit located inside the e-box in the right way.

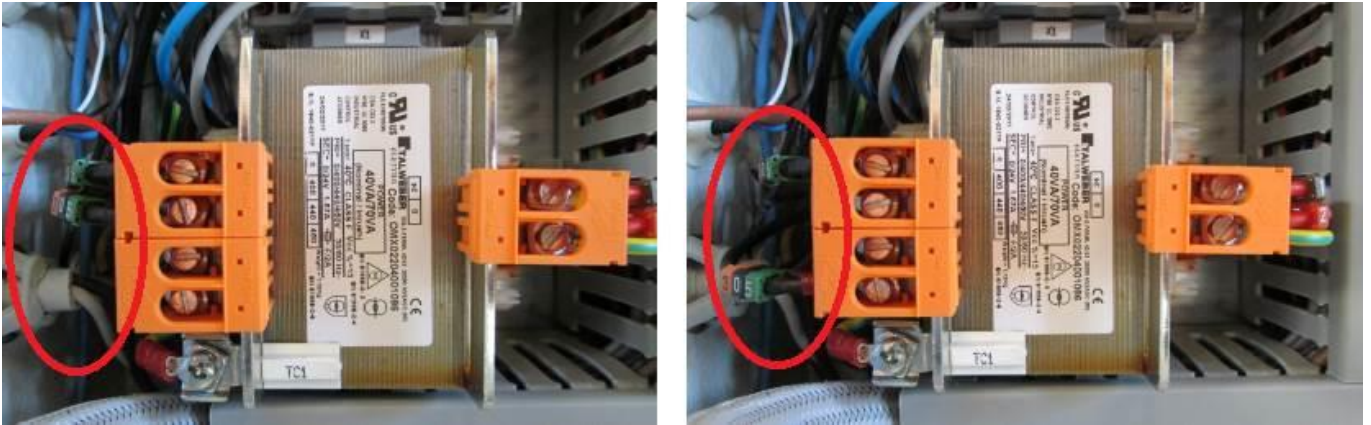

Picture 5-6 – Transformer set at 400V (left), and set at 460V (right)

Unit CE: Factory setting 400/3/50, see picture 5

Unit UL: Factory setting 460/3/60, see picture 6

## Voltage Limitations:

According to CEI EN 60204-1, standard Chiller operation is guaranteed within these ranges:

- Nominal voltage  $\pm 10\%$  [V]
- Nominal frequency  $\pm 1\%$  [Hz]

Please refer to the type label to see which the operating nominal conditions of the unit are.

Nominal conditions	V min [V]	V max [V]	f min [Hz]	f max [Hz]
230 V / 1 ~ / 50 Hz	207	253	49.5	50.5
230 V / 1 ~ / 60 Hz	207	253	59.4	60.6
400V / 3~ / 50Hz	360	440	49.5	50.5
460V / 3~ / 60Hz	414	506	59.4	60.6

For units with special voltages please refer to the type label.

## 7. Process Water / Fluids

The chillers should be filled to the proper level with an inhibited glycol designed for Industrial chillers systems. Do not use automotive antifreeze! The inhibitors used in automotive antifreeze can break down quickly and accelerate the degradation of the coolant base (glycol); as well as promote corrosion in a system. Silicates used in automotive antifreeze coat heat exchangers, resulting in reduced heat transfer. Also, silicates can gel causing fouling and plugging of a system.

The ratio of inhibited glycol to water should be adequate to prevent freezing at the lowest ambient temperature. Check the level with all lines filled. The glycol mixture should be checked periodically (3 to 6 months) for proper concentrations. When filling the system, always use a pre-mixed solution in the proper ratio to maintain freeze and corrosion protection. Demineralized/deionized water is recommended because many municipal water supplies contain large amounts of chlorine, which can react unfavorably with glycol.

**NOTE:** If user's circuit is at least 500mm over the hydraulic connection of the chiller, the fluid in the piping may drain back and overflow the chiller reservoir if the chiller is shut down. This can be prevented by using a check valve in the supply line, and either a solenoid valve on the return line

### **Corrosion protection:**

KKT recommends that Glycol with corrosion protection inhibitor is also used as a rust inhibitor.

The percentages of glycol into the mixture is related to the minimum working temperature of the mixture (that must be in line with the minimum working set point of the unit, please see the technical data of the unit):

Propylene glycol	Dilution %	Freezing point
	20	-8

Ethylene glycol	Dilution %	Freezing point
	20	-8



**CAUTION:** The higher the concentration of glycol the lower the amount of heat rejection you will be able to get out of the fluid.



**CAUTION:** Ethylene glycol and Propylene glycol differs for viscosity and toxicity. Ethylene glycol is less viscous than Propylene one, so it provide a higher efficiency in heat exchanging, and has better performance at low temperatures. For applications where is necessary to ensure a non-toxic process, the propylene glycol based fluids are used because of their low toxicity if ingested; it can be used for example where fluid can enter into accidental contact with beverages, or for industrial processes for food and beverages processing. In some applications propylene glycol use is mandatory.

## 7.1 Waterquality

To keep the hydraulic circuit correct and trouble-free, it is necessary, to check the water quality and if necessary, carry out water treatment. The standard circuit of a water chiller is a half open system, that means, part of the water steams/evaporates out during operation. That means, that the concentration of chloride is getting higher and the system water will cause corrosion on the installed components.

When using water to dilute the mixture, please consider the following:

- It's recommended to use demineralized/deionized water (DM/DI) but not distilled water.
- Do not allow mechanical contamination to get in the water. Use water filters if this could be a problem.
- Water hardness should not be too high. (see below)
- Watch for chemical contamination. If this is to become a problem, treat the water with passivators and/or inhibitors.
- Do not allow biological, slime bacteria, and algae contamination. If this does happen, treat the water with biocides.

KKT recommends that the properties of the water has to be checked in order to identify the quality

### Water quality A (No water treatment necessary):

Fresh water from the tap, free of contamination

Ph-level: 7 - 9

Hardness: <5° dH

Conduction: >50µS/cm

Chlorine: >20 mg/l

### Water quality B (Water treatment is recommended):

Fresh water from tap, free of contamination

Ph-level: 7 - 8,5

Hardness: <10° dH

Conduction: >300µS/cm

Chlorine: >50 mg/l

### Water quality C (Water treatment mandatory):

Fresh water from tap, free of contamination

Ph-level: 7 - 8,5

Hardness: <20° dH

Conduction: >500µS/cm

Chlorine: >100 mg/l

**NOTE:** If user's circuit is at least 500mm over the hydraulic connection of the chiller, the fluid in the piping may drain back and overflow the chiller reservoir if the chiller is shut down. This can be prevented by using a check valve in the supply line, and either a solenoid valve on the return line.

## 8. Ambient temperature

Chiller is designed to operate in the ambient temperature range indicated in the type label.

## 9. Start up of the chiller



**CAUTION:** Work on the electrical and refrigerant circuits may only be performed by qualified personnel!

**NOTE:** The following instruction will guide you through the start up procedure in detailed steps. For a quick commissioning instruction please see appendix A1.

- Turn main switch, control switch, all circuit breakers to switches to the - 0 - (off) position.



Picture 7 - Main switch

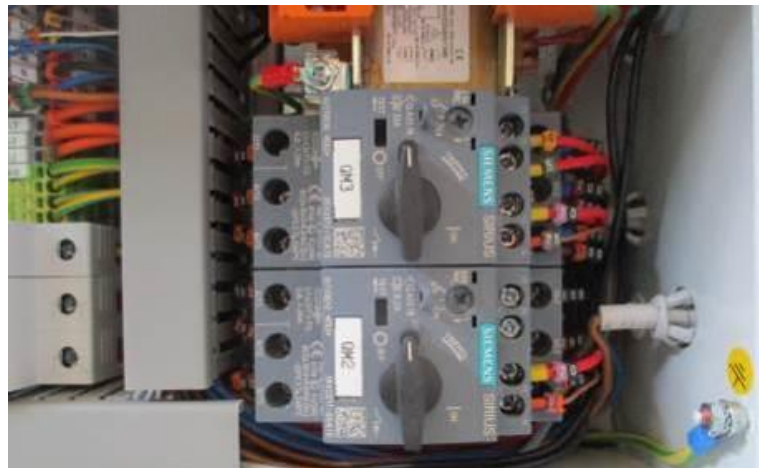

Picture 8 - Circuit Breakers

- Connect water inlet and outlet pipes.
- CHILLER with tank: Remove filling plug, which is located in the top side of the chiller (external)



Picture 8 - Example of filling point

# English

- Fill reservoir with water-glycol mixture until the maximum level is reached. (water quality and treatment should be established according to the application specifications)

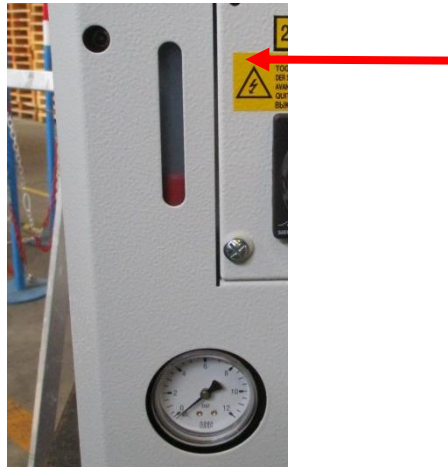

Picture 9 – Max visual level

- Establish main power feed and alarm cable with customer's equipment. When units are provided without power and alarm cables (or industrial connectors), cable on terminal blocks into the electrical box, according to the e-plan enclosed with the unit.



Picture 10 – Electrical connections

- CHILLER with pump: Switch to “On” position the main power switch and circuit breaker for the pump (pumps). All other circuit breakers must stay in the “Off” position.



Picture 11 – pump breaker On



- CHILLER with pump: Main switch should be switched to the - I - (on) position and, for 3 phase version the pump (pumps) should be checked for the correct rotation. (Please note that there is an arrow located at the back part of the pump for direction indication). Reverse two phases R-S-T on the terminal board of the electrical box in case of incorrect rotation to reestablish the correct phase sequence. On chiller with phase check relay the control is automatic.



Picture 12 – Main switch ON



**CAUTION:** The pump must not flat running or in inverse direction; therefore the checking of the correct rotation must be quick

- Switch on the pump; the fluid level must always stay over the minimum level. After the water circuit has run for approx. 5 minutes, switch off the main switch and check again the visual level of the tank; refill the tank in case of need.



Picture 13/14 – tank top up

- Switch off the main switch, than switch all circuit breakers to the “on” position and then the main switch back to “On” position.
- For 3 phase version fan should be checked for the correct rotation. (Please note that there is an arrow located at the side part of the fan-shroud for direction indication). Reverse two phases R-S-T on the terminal board in case of incorrect rotation. The nBoxX is already provided with a phase check controller relay.



Picture 15 – Fan

At this time the Chiller is ready to operate automatically according to the controllers “set point values”. If necessary, set controller according to customers temperature requirements. (Please refer to the manual of the thermostat delivered with the unit).

**NOTE:** The unit works correctly only if the cover panels are mounted on the unit, so if for some reason during the installation of the Chiller they have been removed, please replace them before switching on the unit.



After installation, the ciller does not need intervention by the Qualified Operator. Every calibration operation on thermostats, pressure switch and whatever component of the refrigeration circuit, the personal of the Service KKT Chillers only is competent. For further information on chiller installation, start-up or troubleshooting please contact KKT Service.

## 9.1 Debug Table

The information described below are useful for the service staff. The faults that require the intervention of a refrigeration engineer must be carried out only by specialized staff. Follow all electrical legislation when working on the unit based on valid laws of the countries where the unit is placed.

Chiller		
Problem	Cause	Possible corrective Action
The unit does not start up	No supply voltage	Check the supply main voltage line
	Not working thermostat	Inspect the connection, verify the auxiliary circuit fuses and, if there is no fault, replace the thermostat. 
	The compressor protector (KLIXON, where installed) has switched off	<b>Important:</b> After the shut down of the compressor, the resetting time will depend on the environment of the compressor: In a hot closed environment it will be 2 hours, in ventilated 1 hour. <b>Note:</b> The compressors are protected against high temperatures and currents, with of an internal or external device (Klixon). The internal/external device protects the compressor against the following situations: <ul style="list-style-type: none"> <li>Overheating due to an inadequate cooling of the compressor motor.</li> <li>Blocked compressor due to a high temperature of the motor or a high current.</li> <li>Loose connections which may cause high currents</li> </ul>
It works, but does not cool	There is not enough gas in the equipment	Service by a refrigeration engineer
	Faulty expansion valve	Service by a refrigeration engineer
	Too high heat load	Possible wrong application, to be checked with our staff
	Not working thermostat	Check and correct the parameter settings
	Not correct flow rate on hydraulic circuit	Verify the regulation of hydraulic bypass where installed Verify circuit pressure drop to reach the nominal flow rate
Refrigerant Cycle is not working		
Problem	Cause	Possible corrective Action
Switching of the high pressure switch	The unit does not work. The causes are:	
	<ul style="list-style-type: none"> <li>Dirty condenser</li> </ul>	Clean the condenser with compressed air if it is full of dust, or use proper solvents suitable to remove sludges.

# English

	<ul style="list-style-type: none"> <li>The fan is broken</li> </ul>	Replace the fan 
	<ul style="list-style-type: none"> <li>Wrong fan rotating direction</li> </ul>	Verify the connection on the terminal board of the electrical box; Check the right rotation of the electrical motor (only 3 phase version)
	<ul style="list-style-type: none"> <li>Too high ambient temperature</li> </ul>	Check that the chiller is located in a place that can guarantee suitable ventilation of the refrigerating unit. Check that the ambient temperature does not exceed the max T indicated on the chiller label.
		<p><b>Note:</b> after solving the cause of the fault, start the chiller by pressing the reset button located on the external body of the pressure switch itself (see the picture)</p> 

## Compressor

Problem	Cause	Possible corrective Action
The compressor works continuously and the chiller can't control the liquid temperature: <ul style="list-style-type: none"> <li>too low temperature of the liquid</li> <li>too high temperature of the liquid</li> </ul>		
Too low temperature	Broken thermostat (contact blocked)	Replace the thermostat
Too high temperature	Broken thermostat	Replace the thermostat
	Not enough Freon in the unit	Please ask for the service by a refrigeration engineer
	Too high heat load	Possible wrong application, to be checked with our staff

## Pump

Problem	Cause	Possible corrective Action
No flow rate in the circuit	Pump is down	Check the right rotation of the electrical motor (only 3 phase version) 
	Not correct flow rate on hydraulic circuit	Verify the regulation of hydraulic bypass where installed Verify circuit pressure drop to reach the nominal flow rate

SMP55



## 10. Main view

In main view, the target display shows the value measured by the thermoregulation probe.

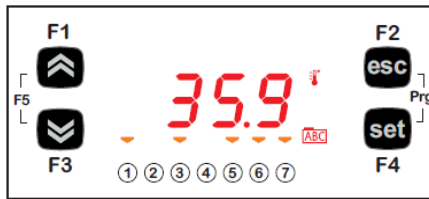

Following table explains the meaning associated to LEDs.

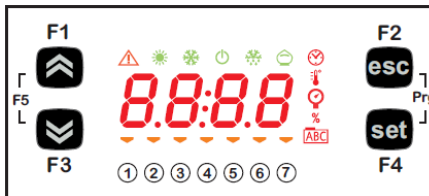

Icon	Description	ON
	Alarm	At least one alarm is active
	Heating	n/a
	Cooling	Compressor is active
	°C	With temperature value displayed
	bar	With pressure value displayed
	Led #1	Pump is active
	Led #2	Compressor is active
	Led #3	Fan is active
	Led #4	n/a
	Led #5	OK Level
	Led #6	n/a
	Led #7	n/a

# English

## 11.Keys

key	Description press and release
UP	Increase a value Go to next label
DOWN	Decrease a value Go to previous label
esc	Exit without saving new settings Go back to previous level
set	Confirm value / exit and save new settings Move to next level (open folder, subfolder, parameter, value) Open state/set Menu
<b>Prg (press together F2+F4)</b>	Access programming Menu

## 12.Parameters

To enter	Main Folder	Sub-folder	PARAMETER	DESCRIPTION	LEVEL	U.M	RANGE MIN - MAX	DEFAULT
Press "set" button	SEt	-	St1	SET-POINT for Fixed Setpoint mode	-	°C	10...35	18
			St1d	SET-POINT for Ambient tracking temperature mode	-	°C	-5...+5	0
	StAt	-	rMAJ	Major release of application	-	-	-	-
			rMin	Minor release of application	-	-	-	-
	EMt	-	EMty	Diagnostic for service	-	-	-	-
	AL	-	- (see Error table)	All active alarms are showed	-	-	-	-
Press "Prg" ("esc"+"set") button	PAR	COnF	St1	SET-POINT for Fixed Setpoint mode	-	°C	10...35	18
			St1d	SET-POINT for Ambient tracking temperature mode	-	°C	-5...+5	0
			dF1	Compressor's relay hysteresis	1	°C	3...6	3
			dF2	HotGas relay hysteresis	1	°C	0...1	0
			StAH	Higher Alarm. Value of temperature (absolute) the passing of which upwards results in the activation of the alarm signal.	1	°C	30..80	40
			StAL	Lower Alarm. Value of temperature (absolute) which, when exceeded downwards, triggers the activation of the alarm signal.	1	°C	-20..20	5
			LrD	Minimum Temperature range for differential control	1	°C	10...HrD	10
			HrD	Maximum Temperature range for differential control	1	°C	LrD...35	35

# English

		Opt	td	Mode of Unit with Ambient tracking temperature OFF (0)= FixedSetpoint (unit works with "St1" SetPoint) ON (1)= DifferentialSetpoint (unit works with "St1d" SetPoint)	1	Flag	OFF/ON (0/1)	OFF (0)
PASS		-		(installation Level) Level 1 access	-	-	0...255	27

## 13. Thermostat Menu

### 13.1. Programming Menu Folders tree

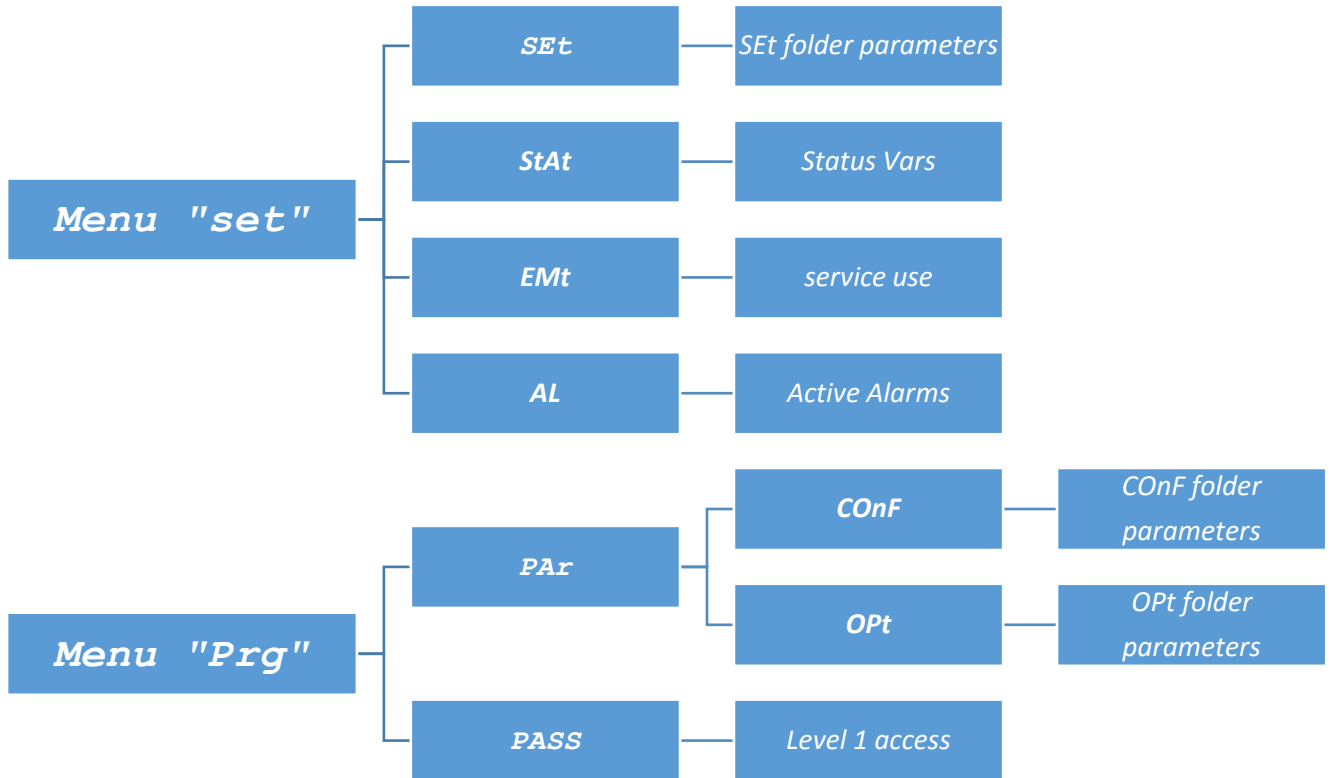





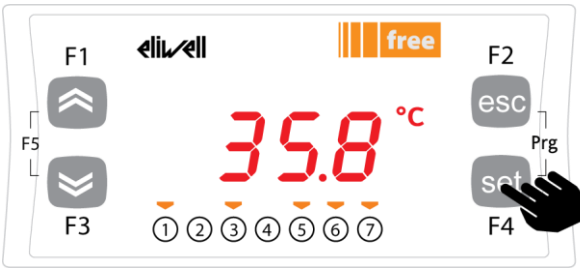

# English

## 13.2. Status / Setpoint menu







(SEt, StAt, AL folders)

Status menu	
	
In main view, press the set key to access the Status / Setpoint menu.	First folder "SEt" appears (Use the UP and DOWN keys to scroll the other folders until you find the label required). folders are (SEt, StAt, AL)
	
Press set key again to view parameters of SEt menu, 1 <sup>st</sup> parameter St1 will be showed	Press set key again to view the value of selected parameter. To modify this value Press the "up" and "down" keys. Press the set key once you have entered the required value.* Press the esc key to exit this display and go back to the previous level. *N.B. pressing the set key will confirm the value entered; Pressing the esc key will take you back to the previous level without saving the value entered.

# English

## 13.3. Programming menu

(PAR/COnF and PAR/OPT folder)

Programming menu	
	
In main view, press Prg to access the programming menu.	Label PAR appears Press set key again to view parameters' folders
	
1 <sup>st</sup> folder is COnF. Press set again to view 1 <sup>st</sup> parameter of the folder (Use the UP and DOWN keys to scroll the other labels until you find the label required). COnF and OPT subfolders are available.	1 <sup>st</sup> parameter is St1 (Use the UP and DOWN keys to scroll the other labels until you find the label required).
	
Press set to view St1 value	St1 value will be showed



Note: to see parameters of "Level 1" insert the password (see paragraph [Entering a password to access to Installation level "Level 1"](#))

The information described below are useful for the user staff. The faults that require the intervention of a refrigeration engineer must be carried out only by specialized staff. Follow all electrical legislation when working on the unit based on valid laws of the countries were the unit is placed.

# English







## 13.4. Entering a password to access to Installation level “Level 1”

To view parameters visible for the given password, open folder PASS (press esc and set together [esc+set] from the main display and search the folder “PASS” using the up/down keys) and set the PASS value (27).

Setting password		
		
In main view, press Prg to access the programming menu.	Label PAR appears Pressing the two keys will open the menu containing the list of folders. Use the "up" and "down" keys to scroll the list until you find the PASS folder.	Press the set key to open the PASS folder. Enter the password (27) from here, press the set key and exit. Now open and view parameters to change a value (see chapter <a href="#">Parameters</a> ).

## 13.5. Changing of Setpoint mode (Differential thermostat option)

Instructions are provided below on how to change from Differential to Fix SetPoint function of SMP55.

Enter to “level 1” with password (see chapter 4.4)		
		
Press the esc and set keys together to open the parameters menu. This will open the PAR menu.	The PAR parameters menu contains all device parameter folders. Press the set key to view all folders.	The first folder the controller shows is the CONf configuration folder. Press one time  to view “Opt” → press the set key again to modify individual “Opt” parameters.
		
The “td y” parameter will be shown on the device	Press the set key to view the value (Off or On) of the parameter	To disable Differential function and change to Fix Set Point set to “OFF” the value To return to Differential SetPoint function set this value to “ON”

**WARNING:** Turn off and then on again whenever you change the configuration parameters to prevent malfunctioning on configuration and / or ongoing timings.

**Note:** To change the setpoint please refer to chapter [Status / Setpoint menu](#)

## 14.Errors table

Error Messages table

Label	Description	Reset	Common alarm	Stops			Type of Error
				Comp.	Fan	Pump	
Er01	Flow alarm	AUTO (after flow replace)	Open	-	-	-	Warning
Er02	Refrigerant High pressure alarm	MANUAL (High Pressure Switch)	Open	OFF	OFF	-	Alarm
Er04	Compressor fault	MANUAL (Circuit Breaker)	Open	OFF	OFF	-	Alarm
Er06	Pump fault	MANUAL (Circuit Breaker)	Open	OFF	OFF	OFF	Alarm
Er07	Water temperature probe fault	AUTO (after replacing/repairing of the probe)	Open	OFF	OFF	-	Alarm
Er08	External temperature probe fault	AUTO (after replacing/repairing of the probe)	Open	OFF	OFF	-	Alarm
Er09	Antifreeze alarm	AUTO (after increase of the temperature $t > \text{antifreeze set}$ )	Open	OFF	OFF	-	Alarm
Er11	Fluid min Temperature alarm	AUTO (after increase of the temperature $t > 5^{\circ}\text{C}$ ) OL( $t > 15^{\circ}\text{C}$ )	Open	-	-	-	Warning
Er12	Fluid max Temperature alarm	AUTO (after temperature drops $t < 40^{\circ}\text{C}$ )	Open	-	-	-	Warning
Er13	Tank Min level alarm	AUTO (after refill of the tank)	Open	OFF	OFF	OFF	Alarm
Er19 <sup>1</sup>	Refrigerant Pressure Sensor Fault	Automatic (after replacing / repairing of the sensor)	Open	OFF	OFF	-	Alarm

<sup>1</sup> available if BPG option is mounted

# English

## 15. Hot-Gas Regulation (only with installed option BPG)

### 15.1. Hot-Gas with Fixed Setpoint

The regulator gets the temperature measure from the thermoregulation probe; the setpoint is  $18^{\circ}\text{C} \pm 0,5^{\circ}\text{C}$  for Water+Glycol units.

Control action is proportional to the error and it reaches saturation (100%) when the temperature is less than the setpoint minus the (param. Df1 "Hysteresis") divided by 2.

The Compressor Setpoint will be  $\text{WS} = \text{WS1} - 1^{\circ}\text{C}$  with Hysteresis  $3^{\circ}\text{C} (\pm 1,5^{\circ}\text{C})$

Fan is ON only when compressor is ON

<i>Fixed Setpoint Settings ("td" = 0 or OFF)<sup>2</sup></i>			
Type	Parameter	Factory Setting [ $^{\circ}\text{C}$ ]	Range of Setting [ $^{\circ}\text{C}$ ]
Water+Glycol	St1	18	13 - 35
	WS1 <sup>1</sup>	/	13 - 35
All	Df1	0,1	0,1-1

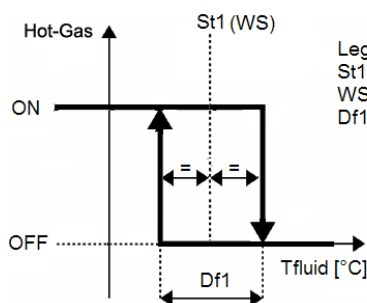

Legend:  
St1 = thermostat set point  
WS = chiller working set point  
Df1 = hysteresis

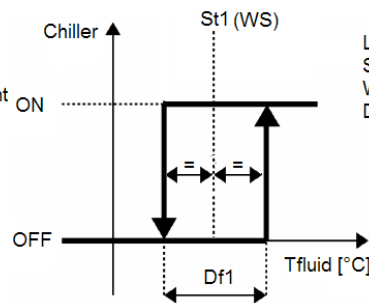

Legend:  
St1 = thermostat set point  
WS = chiller working set point  
Df1 = hysteresis

### 15.2. Hot-Gas with Differential Setpoint (Ambient tracking)

The regulator gets the temperature measure from the thermoregulation probe; the setpoint is Ambient Temperature  $\pm 0,5^{\circ}\text{C}$ .

If the ambient temperature is out of working setpoint range the working setpoint will assume the maximum value (if the ambient temperature is greater) or the minimum value (if the ambient temperature is less).

Control action is proportional to the error and it reaches saturation (100%) when the temperature is less than the setpoint minus the (param. Df1 "Hysteresis") divided by 2.

The Compressor Setpoint will be  $\text{WS} = \text{WS1} - 1^{\circ}\text{C}$  with Hysteresis  $3^{\circ}\text{C} (\pm 1,5^{\circ}\text{C})$

Fan is ON only when compressor is ON

<i>Differential Setpoint Settings with TD option selected ("td" = 1 or ON)<sup>2</sup></i>			
Type	Parameter	Factory Setting [ $^{\circ}\text{C}$ ]	Range of Setting [ $^{\circ}\text{C}$ ]
Water+Glycol	St1d	0	-5 - +5
	WS1 <sup>1</sup>	/	13 - 35
All	Df1	0,1	0,1-1

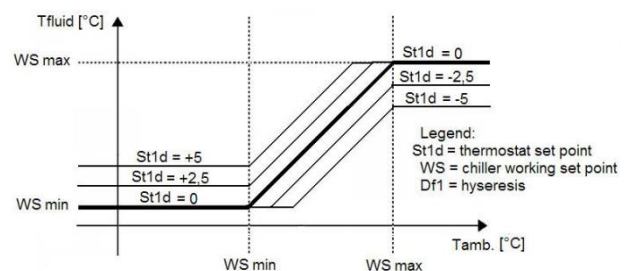
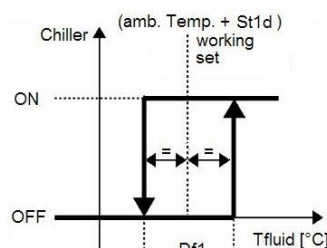
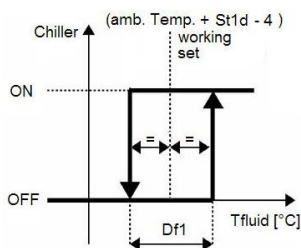

Legend:  
St1d = thermostat set point  
WS = chiller working set point  
Df1 = hysteresis

<sup>1</sup> read only parameter

<sup>2</sup> to change the mode of setpoint (differential; fixed) please refer to „[Changing of Setpoint mode](#)“ chapter

## 16. Cooling (without option Hot-Gas BPG)

### 16.1. Cooling with Fixed Setpoint

The regulator gets the temperature measure from the thermoregulation probe; the setpoint is  $18^{\circ}\text{C} \pm 1,5^{\circ}\text{C}$  for Water+Glycol units.

Control action is proportional to the error and it reaches saturation (100%) when the temperature is greater than the setpoint plus the (param. Df1 "Hysteresys") divided by 2.

Fan is ON only when compressor is ON

Fixed Setpoint Settings ("td" = 0 or OFF) <sup>2</sup>			
Type	Parameter	Factory Setting [°C]	Range of Setting [°C]
Water+Glycol	St1	18	11,5 - 35
	WS1 <sup>1</sup>	/	11,5 - 35
All	Df1	3	3-6

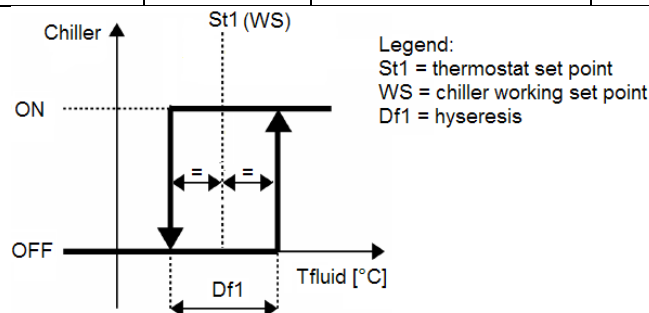

### 16.2. Cooling with Differential Setpoint (Ambient tracking)

The regulator gets the temperature measure from the thermoregulation probe; the setpoint is Ambient Temperature  $\pm 1,5^{\circ}\text{C}$ .

If the ambient temperature is out of working setpoint range the working setpoint will assume the maximum value (if the ambient temperature is greater) or the minimum value (if the ambient temperature is less).

Control action is proportional to the error and it reaches saturation (100%) when the temperature is greater than the setpoint plus the (param. Df1 "Hysteresis") divided by 2.

Fan is ON only when compressor is ON



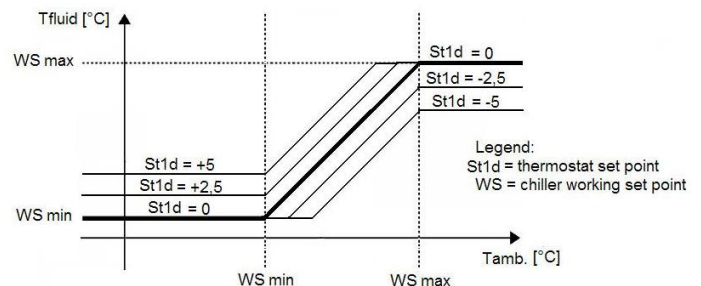
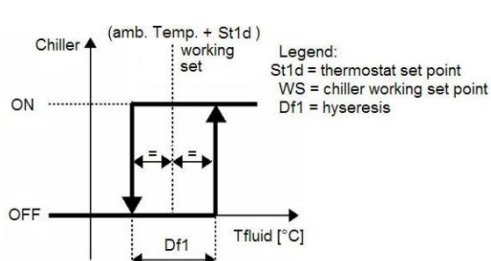

Differential Setpoint Settings with TD option selected ("td" = 1 or ON) <sup>2</sup>			
Type	Parameter	Factory Setting [°C]	Range of Setting [°C]
Water+Glycol	St1d	0	-5 - +5
	WS1 <sup>1</sup>	/	11,5 - 35
All	Df1	3	3-6



<sup>1</sup> read only parameter

<sup>2</sup> to change the mode of setpoint (differential; fixed) please refer to „Changing of Setpoint mode“ chapter

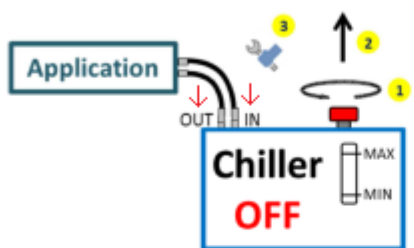
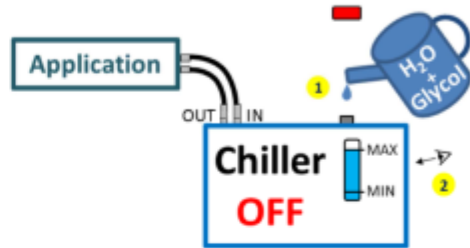
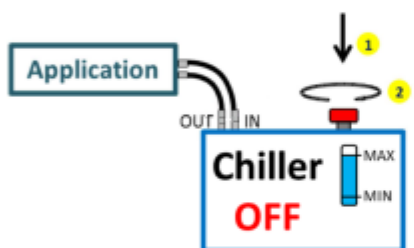
## Commissioning „Open loop cooling circuit“

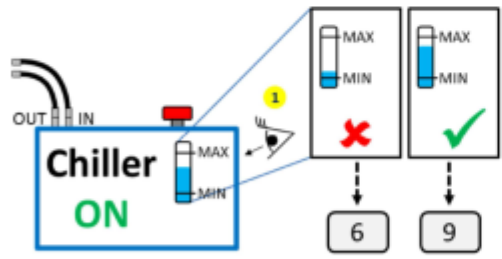
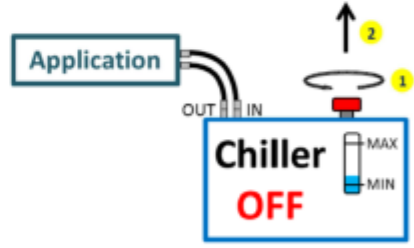
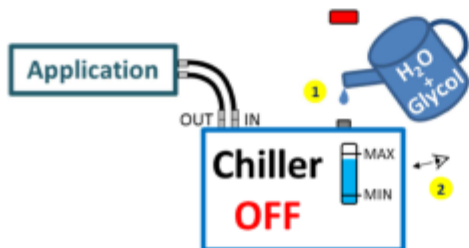
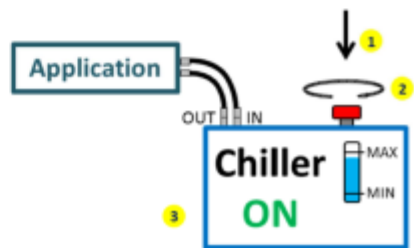
Canister 	Tools 	Time 
<div style="border: 1px solid gray; border-radius: 10px; width: 40px; height: 40px; margin: 0 auto; display: flex; align-items: center; justify-content: center; margin-bottom: 10px;">1</div> 	<div style="border: 1px solid gray; border-radius: 10px; width: 40px; height: 40px; margin: 0 auto; display: flex; align-items: center; justify-content: center; margin-bottom: 10px;">2</div> 	
<div style="border: 1px solid gray; border-radius: 10px; width: 40px; height: 40px; margin: 0 auto; display: flex; align-items: center; justify-content: center; margin-bottom: 10px;">3</div> 	<div style="border: 1px solid gray; border-radius: 10px; width: 40px; height: 40px; margin: 0 auto; display: flex; align-items: center; justify-content: center; margin-bottom: 10px;">4</div> 	
<div style="border: 1px solid gray; border-radius: 10px; width: 40px; height: 40px; margin: 0 auto; display: flex; align-items: center; justify-content: center; margin-bottom: 10px;">5</div> 	<div style="border: 1px solid gray; border-radius: 10px; width: 40px; height: 40px; margin: 0 auto; display: flex; align-items: center; justify-content: center; margin-bottom: 10px;">6</div> 	
<div style="border: 1px solid gray; border-radius: 10px; width: 40px; height: 40px; margin: 0 auto; display: flex; align-items: center; justify-content: center; margin-bottom: 10px;">7</div> 	<div style="border: 1px solid gray; border-radius: 10px; width: 40px; height: 40px; margin: 0 auto; display: flex; align-items: center; justify-content: center; margin-bottom: 10px;">8</div> 	

Maintenance / Check and Inspections



**CAUTION:** Before any maintenance intervention, not needing the machine running, disconnect the supply voltage and put the signal MAINTENANCE IN PROGRESS next to the lockable main switch in “Off” position.

Refrigeration and hydraulic circuits are accessible by removing the two lateral panels or the frontal one.



Picture 15 – Access points to the chiller

Carrying out the tests and check program listed below will extend the life of the equipment and avoid possible breakdowns.

Please Note: it is of utmost importance the compliance with Regulation (EU) No 517/2014, regarding mandatory regular leakage-check program, as described in Section 2 of this Operation and Maintenance Manual.

- Check mechanical working of the compressor . Control the absence of metallic vibrations and not too high noises and temperatures on the compressor head during running to verify its regular working.



Picture 16 – Compressor placement for nBoxX 1.7



Picture 17 – Compressor placement for nBoxX 3.5 , nBoxX 5.0 , nBoxX 6.5



- Check the operation of the fan.



**Picture 18 – Fan placement**

- Check the electrical alarm systems and controls.
- Check the filling of the tank (visual level). If the system is filled with a glycol-mix, refill only with the same mix. Only water will reduce the concentration of glycol.
- Check that pressure, flow rate and temperature values of the hydraulic circuit are included into the limits indicated on the machine label.
- If the chiller is equipped with an air filter, the filter has to be changed/cleaned monthly, or, if required in a shorter time interval
- Inspect the condenser monthly on the external side to see if it is clean. The fins of the condenser must not have any dust deposits or residual products or sludges on their surface .



**Picture 19 – Condenser external surface for nBoxX 1.7**



**Picture 20 – Condenser external surface for nBoxX 3.5 , nBoxX 5.0 , nBoxX 6.5**

- The condenser must be cleaned in monthly intervals, or, if required in shorter time intervals.
- If the Chiller is equipped with a filter on the hydraulic side, the filter has to be checked/cleaned monthly, or if required, in a shorter time interval
- It's recommended to change the water glycole mixture 20% every year (every 2 years if it's a 30% or 50% glycole mixture) to allow the operation of the unit in the best conditions.
- Longer standstill of the chiller requires draining of the tank and complete water circuit. Open the ball valve at the end of the draining hose to drain the circuit. When the drain operation is finished close again.

- 
- For a new installation, it is recommended to empty the hydraulic circuit. Please, refer to chapter 4 for the lifting of the unit and chapters 7 and 11 for connection and start up.
  - Refrigeration circuit is subjected to high stationary and operating pressures.
  - Please, familiarize with components described in Appendix B2 prior to proceeding with Service and Maintenance requiring refrigeration circuit sectioning.
  - No device with internal volume greater than 25lt is installed on the refrigeration circuit, thus no further inspection from notified bodies is required according to D.M. nr.309 – December the 1st 2004.
  - On special chiller which are designed to work in outside ambients (OD version), and also equipped with multipolar connector, it's necessary to change connector gasket every two years. The code of the gasket is indicated in the spare part list of the unit. Use Loctite 407 or similar to fix the gasket.

The customer is intended to verify compliance with all additional local requirements in force.

**APPENDIX C**

**Electrical and mechanical components**

Refrigeration and hydraulic circuits are accessible by removing the two lateral panels.

<p><b>Compressors nBoxX 1.7</b></p> 	<p><b>Compressors nBoxX 3.5 , nBoxX 5.0 , nBoxX 6.5</b></p> 	<p><b>Dehydrator Filter</b></p> 
<p><b>Fan</b></p> 	<p><b>High pressure switch</b></p> 	<p><b>Condenser</b></p> 
<p><b>Thermostatic Valve</b></p> 	<p><b>Evaporator</b></p> 	<p><b>Pump</b></p> 

APPENDIX D

EC declaration of conformity



**EG-Konformitätserklärung**  
*EC declaration of conformity*  
*Déclaration de conformité CE*

**Gerät (machine; machine):** Industriekühler (Industrial Chiller, Refroidisseur industriel)  
**Maschinentyp (type; type):** Alle Modelle der Baugruppe (All models of the component, Tous les modèles des module)  
nBoxX 1.7, nBoxX 3.5, nBoxX 5.0, nBoxX 6.5  
**Zur bestimmungsgemäßen Verwendung als (usage; utilisation):** Prozesskühler (Process Water Chiller, Refroidisseur de processus)

Hiermit erklären wir die Konformität des Gerätes im Sinne folgender Richtlinien und Normen.  
Herewith we declare the conformity of the machine according to following instructions and standards.  
Par la présente, nous déclarons que cette machine satisfait les dispositions suivantes.

**Richtlinie (instruction; directives):** Maschinenrichtlinie 2006/42/CE  
(EC machinery directive, Directives CEE relatives aux machines)  
Druckgeräterichtlinie 2014/68/EU  
(PED; Directives CEE relatives aux pressions )  
Elektromagnetische Verträglichkeit 2014/30/EU  
(EMV-instructions, Compatibilité électromagnétique)  
Niederspannungsrichtlinie 2014/35/EU  
(Low voltage instructions, Directives CEE relatives aux basses tensions)

**Angewandte harmonisierte Normen (applied harmonized standards; normes harmonisées utilisées):** EN 378 Teil/part1-3  
EN ISO 12100  
EN 60204 Teil 1  
EN 61000-6-2:2005  
EN 61000-6-4:2007, A1:2011 ;

**benannte Stelle (Notified Bodies; autorité, corps notifiés):** Nicht erforderlich  
(Not required, non requise)

**Verantwortlicher des Herstellers (person responsible of the manufacturer; responsable chez le fabricant):**

Kasendorf, 2018-05-25

i.V. Markus Zöbler  
Leiter Entwicklung Kühlung  
Manager Development Cooling